

FE65JS

天花式全金屬強力工業風扇

- 單速（可配調速器），220 - 240 V, 1 Ph, 50 Hz。
- 配外置金屬電容器按 IEC60252 之標準檢測，規格為 S2, Class A. 壽命達30,000小時。
- 金屬風扇普通網外表靜電噴塗，美觀耐用。
- 風扇可360度轉向（配搖擺開關），並可簡易調校送風角度，立體循環送風。
- 所有型號均按 IEC60335-2-80 之標準檢測，並已領有歐盟安全認證。
- 扇葉採用鋁合金壓鑄而成，平衡技術校正，高速運轉平穩不變形。
- E 級絕緣，內置恒溫器保護裝置，同步電機搖擺，節能靜音。
- 功率因數（Power Factor）=0.97。



性能參數表

型號 (香港規格)	型號說明	扇葉直徑 inch/mm	額定電壓 V/Ph/Hz	電機功率 W	最高轉速 RPM	最高風量 m ³ /h	最高噪音 dB (A)
FE65JS	外置電容 疏網吸頂扇	25" / 650	220-240/1/50	160	1400	9200	72

噪音值是在距離風扇2米測量

產品安裝尺寸 (mm) 及維護

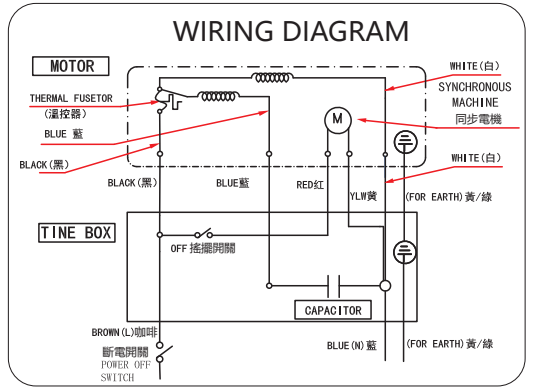
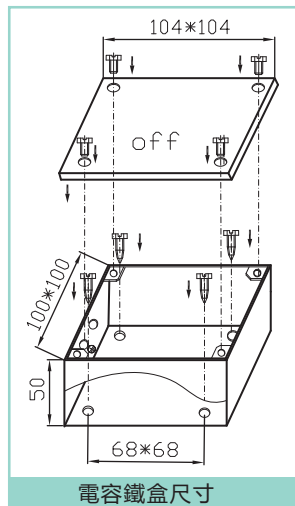
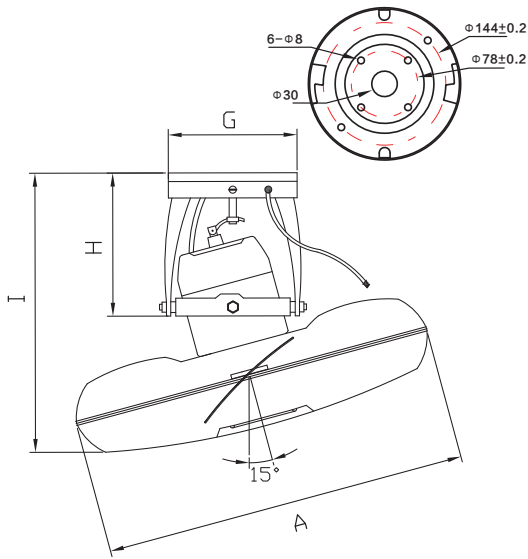

Model No	A	I	H	G
FE65JS	690	440	200	179

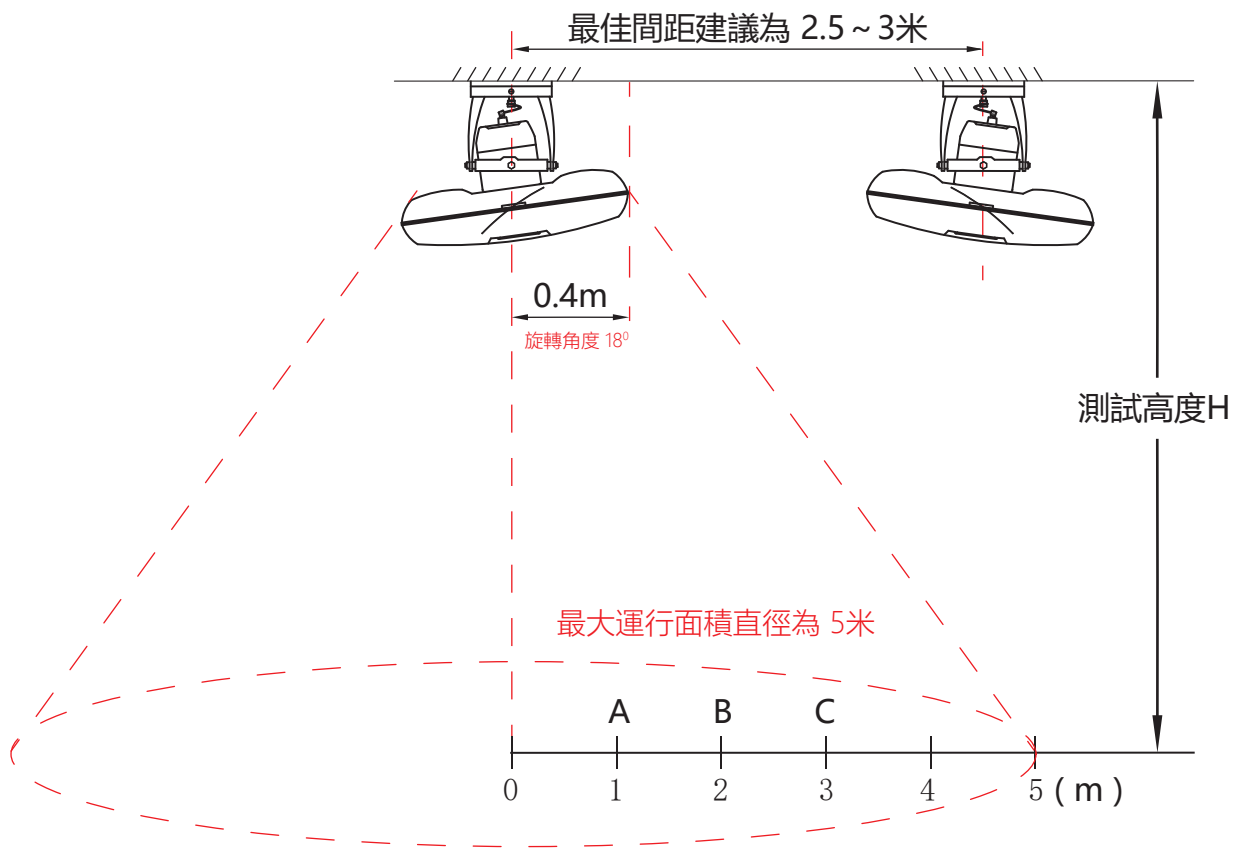

風扇各高度測試點的風速

單位: m/s

工程安裝使用建議

環境溫度 ≤ 45°C

	FE40		FE45		FE50		FE65	
	3米	4米	3米	4米	3米	4米	3米	4米
測試高度H								
測試點 A	0.99	0.9	1.21	1.1	1.32	1.2	1.54	1.4
測試點 B	1.43	1.3	2.15	1.95	2.56	2.33	1.70	1.54
測試點 C	0.66	0.6	1.89	1.72	2.13	1.94	2.59	2.35

	面積 (m ²)	高度 (m)	建議型號 (Model)	數量 (臺)
學校課堂	36	2	FE40/FE45	4
學校禮堂	36	3	FE50	4
物流倉庫	36	4	FE65	6

建議使用調速器

OPTIONAL SPEED CONTROLLER (NOT INCLUDED IN THE UNIT, CUSTOMER NEED TO PURCHASE THE CONTROLLER THEMSELVES)

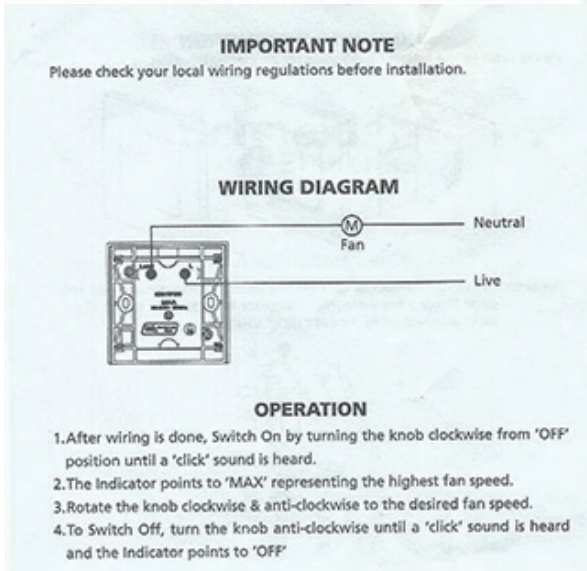
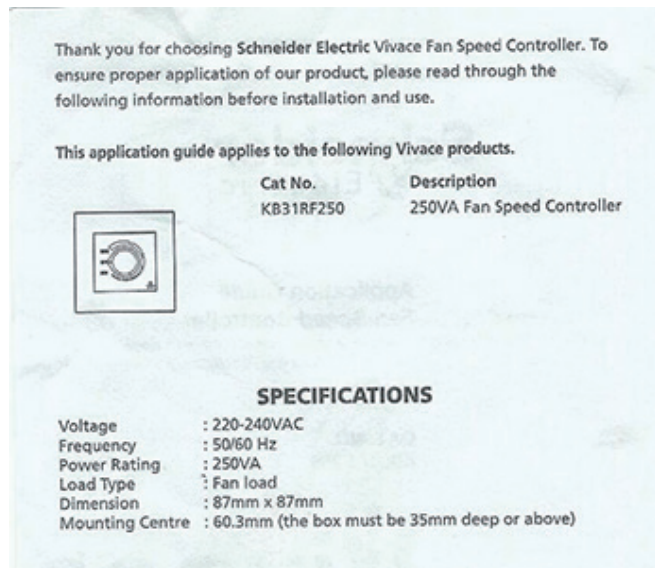
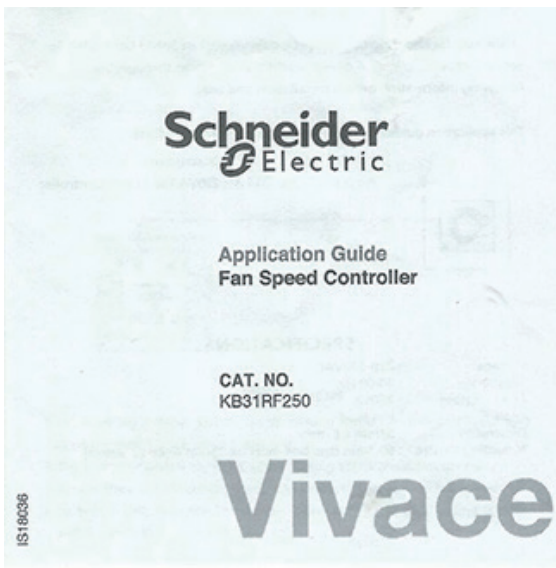

ATTENTION:

THE RATED POWER OF THE CONTROLLER MUST BE LARGER THAN 180W. OTHERWISE, THE FAN WILL BE DAMAGED !

SAFETY PRECAUTIONS

1. Do not use under the following situations
 - 1) Near to gaseous fuel cooker .
 - 2) Place full of inflammable gas.
 - 3) Place expose to rain or water pour.
 - 4) Near insecticide, oil corrosive solvent.
 - 5) High temperature.
 - 6) High humidity .
 - 7) Near chemicals, oil, dust area.
2. Avoid continuously exposure of direct wind from the fan, It may cause discomfort.
3. Do not put your fingers into the guard or any moving part of the fan, Causing injury.
4. Make sure all screws and connection are tightly screwed and secured. Causing injury.
5. Installation must strictly follow to wiring diagram provided, Can cause electric shock, current leakage and fire if miswiring.
6. Ensure area of mounting fixture has sufficient strength, Do not fix at area exposed to strong vibration and knocking.
7. Never try to apart, repair or modify this product. Contact the dealer for repairing this product.
8. Disconnect power supply before cleaning. Otherwise it may cause electric shock.
9. Installation must be done by qualified electrician.
10. The safety wire must be always connected.
11. Do not connect this unit to power supply other than destined country rated voltage.

ZERTIFIKAT ◆ CERTIFICATE ◆ 認證證書 ◆ CERTIFICADO ◆ CERTIFICAT



Product Service

Attestation of Conformity

No. N8A 17 10 72582 029

Holder of Certificate: WING TON FAN INDUSTRY LIMITED

1B Kam Shing Industrial Building
1-11 Kwai Wing Road
Kowloon
HONG KONG

Product: Fans
(Ceiling Fan)

Model(s): FE40JA, FE40JB, FE40JC, FE40JD, FE40JR, FE40JS,
FE45JA, FE45JB, FE45JC, FE45JD, FE45JR, FE45JS,
FE50JA, FE50JB, FE50JC, FE50JD, FE50JR, FE50JS,
FE65JA, FE65JB, FE65JC, FE65JD, FE65JR, FE65JS

Parameters:

Rated Input :	220-240VAC, 50Hz; 110W, 0.52A (for FE40JA, FE40JB, FE40JC, FE40JD, FE40JR and FE40JS) 140W, 0.63A (for FE45JA, FE45JB, FE45JC, FE45JD, FE45JR and FE45JS) 150W, 0.66A (for FE50JA, FE50JB, FE50JC, FE50JD, FE50JR and FE50JS) 160W, 0.75A (for FE65JA, FE65JB, FE65JC, FE65JD, FE65JR and FE65JS)
Protection Class :	I
Degree of Protection :	IPX0

Tested according to: EN 60335-2-80:2003/A2:2009
EN 60335-1:2012/A12:2017
EN 62233:2008

This Attestation of Conformity is issued on a voluntary basis according to the Low Voltage Directive 2014/35/EU relating to electrical equipment designed for use within certain voltage limits. It confirms that the listed equipment complies with the principal protection requirements of the directive and is based on the technical specifications applicable at the time of issuance. It refers only to the particular sample submitted for testing and certification. See also notes overleaf.

Test report no.: 681101718201

Date, 2017-11-02

(Kelvin Zeng)



After preparation of the necessary technical documentation as well as the EU declaration of conformity the required CE marking can be affixed on the product. The declaration of conformity is issued under the sole responsibility of the manufacturer. Other relevant EU-directives have to be observed.

Page 1 of 1

TÜV SÜD Product Service GmbH · Zertifizierstelle · Ridlerstraße 65 · 80339 München · Germany

TÜV®



Ref. Certif. No.

SG PSB-HS-05617

IEC SYSTEM FOR MUTUAL RECOGNITION OF TEST CERTIFICATES FOR ELECTRICAL EQUIPMENT (IECEE) CB SCHEME

CB TEST CERTIFICATE

Product

Fans
(Ceiling Fan)

Name and address of the applicant

**Sam Hing Cheung Fans
And Equipment Limited**
Flat B, 1/F., Kam Shing Industrial Building
1-11 Kwai Wing Road
Kwai Chung
HONG KONG

Name and address of the manufacturer

Sam Hing Cheung Fans And Equipment Limited
Flat B, 1/F., Kam Shing Industrial Building, 1-11 Kwai Wing Road,
Kwai Chung, HONG KONG

Name and address of the factory

**FOSHAN SHUNDE SAM HING CHEUNG FANS AND EQUIPMENT
LIMITED**
No.1 Building, No.1 Road Guangda Market, Leiliu Town, Shunde
District, 528322 Foshan, PEOPLE'S REPUBLIC OF CHINA

Ratings and principal characteristics

Rated Input : 220-240VAC, 50Hz.
See test report for details
Protection Class : I
Degree of Protection : IPX0

Model/type Ref.

FE40JA, FE40JB, FE40JC, FE40JD, FE40JR, FE40JS, FE45JA,
FE45JB, FE45JC, FE45JD, FE45JR, FE45JS, FE50JA, FE50JB,
FE50JC, FE50JD, FE50JR, FE50JS, FE65JA, FE65JB, FE65JC,
FE65JD, FE65JR, **FE65JS**

A sample of the product was tested and found to be in conformity with

IEC 60335-1:2010
IEC 60335-1:2010/AMD1:2013
IEC 60335-1:2010/AMD2:2016
IEC 60335-2-80:2015

as shown in the Test Report Ref. No. which forms part of this certificate

211-700425-000

This CB Test Certificate is issued by the National Certification Body

CBS 072582 0037 Rev. 00

Date, 2019-09-17

(Darius Guo)

Page 1 of 2
TÜV SÜD PSB Pte Ltd • 1 Science Park Drive • Singapore 118221



PSB Singapore

Film Capacitors – AC Capacitors

Motor run capacitors

CBB65

Construction

- Metallized polypropylene film
- Aluminum can and top
- Filling material: soft polyurethane resin

Features

- Self-healing properties
- Low dissipation factor
- Overpressure disconnection safety device
- S2 safety class as per IEC-60252-1(ed-2) am1
- High insulation resistance
- EN 60252-1 compliance

Typical applications

- For general sine wave application, mainly as motor run

Terminals

- 2+2 fast-on terminal 6.3 x 0.8mm #250 style, others on request

Mounting Parts (Optional)

- Threaded stud at bottom of can (M8, Max torque= 5 Nm for 50 mm diameter)







Technical data and specifications	
Reference standards	DIN EN 60252-1: 2011 + A1, IEC 60252-1 (ed 2) am1 UL 810, GB/T3667.1
Safety class to IEC 60252-1	S2
Life expectancy to IEC 60252-1	450 V : 30000 h (Class A)
Class of Operation	Class A
Capacitance Tolerance	+/- 5%
Rated Capacitances	3uF - 65uF
Rated frequency	50/60 Hz
Rated voltage V_{rms}	450 V , others on request
Maximum ratings	
Maximum permissible voltage V_{max}	$1.1 \cdot V_R$ (V_R = Rated voltage)
Maximum permissible current I_{max}	$1.3 \cdot I_R$ (I_R = Rated current)

Film Capacitors – AC Capacitors

Motor run capacitors

CBB65

Test data	
AC test voltage terminal to terminal V_{TT}	$2.0 \cdot V_R, 2 \text{ s}$
Insulation voltage terminals to case	3000 V AC, 2 s
Insulation resistance R_{ins} or time constant at +20 °C, rel. Humidity $\leq 65\%$ (minimum as-delivered values)	10000 s
Dissipation factor $\tan \delta$ at +20 °C	$\leq 7 \cdot 10^{-3}$ (1 kHz)
Maximum rate of voltage rise dV/dt_{max}	10 V/ μs
Climatic data	
Climatic category	40/085/21 to IEC 60068-1
Lower category T_{min}	-40° C
Upper category T_{max}	+85° C
Damp heat test t_{test}	21 days
Mechanical and thermal properties of terminal insulator material	
Terminal material <ul style="list-style-type: none"> ■ UL 94 V0 compatible ■ Glow wire test to IEC60335-1 Test temperature +750 °C ■ Part is compatible to EN 60335-1 	Self-extinguishing within 2 seconds of withdrawing glow wire without igniting wrapping tissue of GWT
Approvals: See table for approved ratings	
 US UL File E 238746	Approved component 10000 AFC
VDE EN 60252-1 	Approved up to 65 μF , 450 V / 85°C : 30000 h (Class A)
CQC 	Approval on request
	Compliance to LV directive 2014/35/EU

Dimensional drawing and marking

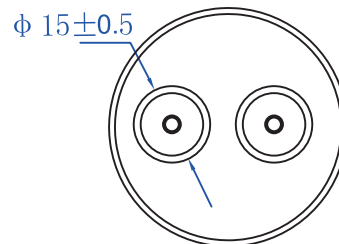
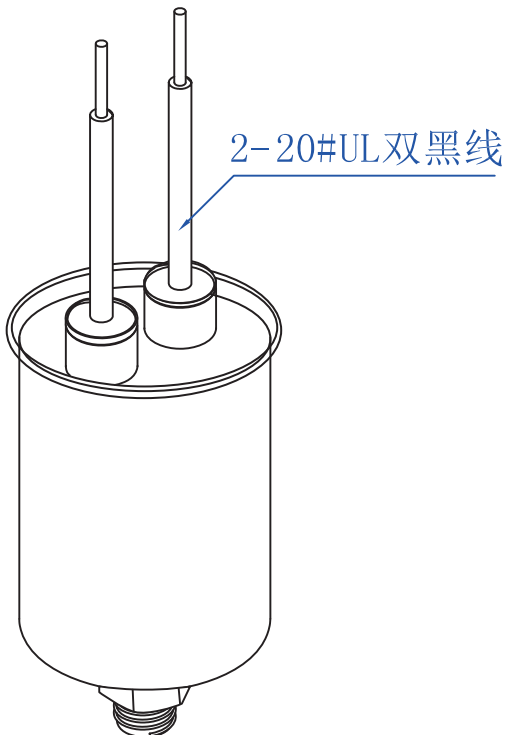
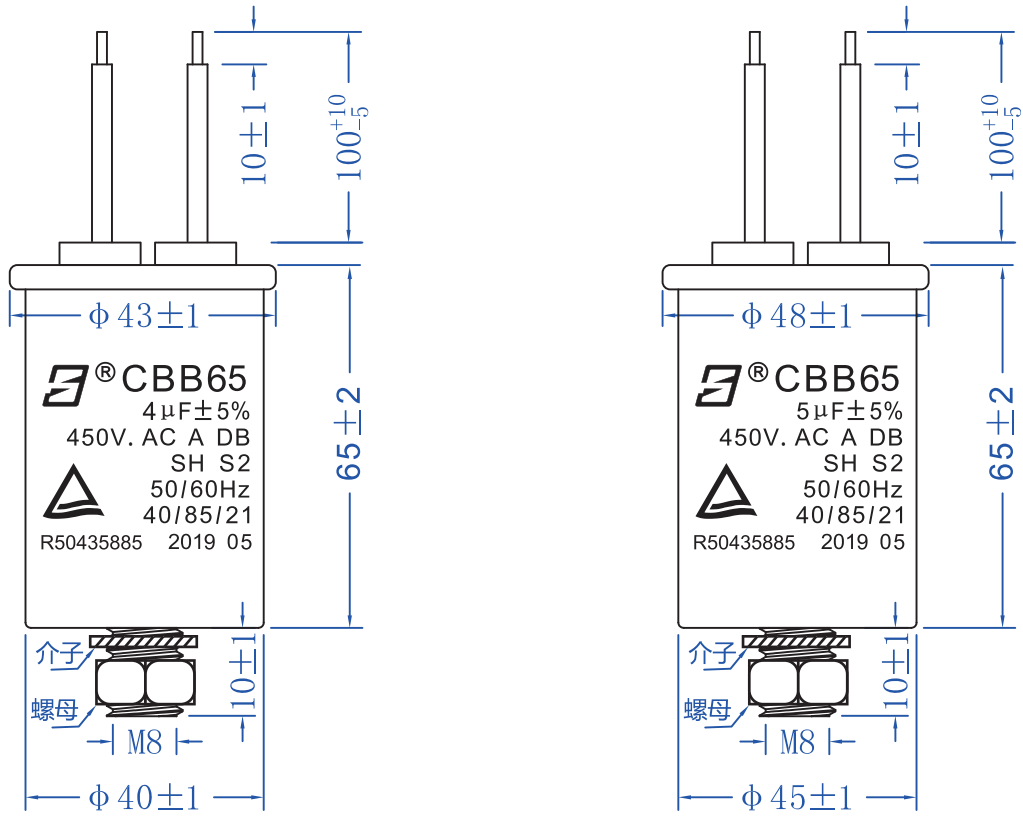

Zertifikat

Certificate



Zertifikat Nr. *Certificate No.*
R 50435885

Blatt *Sheet*
0001

Ihr Zeichen <i>Client Reference</i>	Unser Zeichen <i>Our Reference</i>	Ausstellungsdatum <i>Date of Issue</i>	<i>(day/mo/yr)</i>
	05-YFC-50186558 001	10.05.2019	

Genehmigungsinhaber <i>License Holder</i>	Fertigungsstätte <i>Manufacturing Plant</i>
Xunde Electrical and Electronic Co., Ltd. Juwei Industry Zone Beijiao, Shunde Foshan, Guangdong P. R. China	Xunde Electrical and Electronic Co., Ltd. Juwei Industry Zone Beijiao, Shunde Foshan, Guangdong P. R. China

Prüfzeichen *Test Mark*



Geprüft nach *Tested acc. to*
EN 60252-1:2011+A1

Zertifiziertes Produkt (Geräteidentifikation) *Certified Product (Product Identification)*

Lizenzentgelte - Einheit *License Fee - Unit*

Capacitor (AC Motor Capacitors)

Type Designation	: CBB65	5
Trademark	: Xunde Xunde (logo)	
Rated Voltage	: AC 400V/450V	
Rated Frequency	: 50Hz/60Hz	
Rated Capacitances	: 3µF-65µF (See Appendix 1)	6
Climatic Category	: 40/85/21	
Capacitance Tolerance	: ±5%	
Class of Safety Protection	: S2	
Class of Operation	: Class A	
Self-healing Capacitor	: Yes	
Type of Operation	: Continuous	
Type of termination	: Tabs of flat Quick-connector (4.8x0.5mm; 6.3x0.8mm)	

Remark : The labelling requirements acc. to EU Directive 2001/95 have to be observed for distribution within the EEA. The installation has to be carried out according to installation instruction accompanying the products.

11

ANLAGE (Appendix): 1

Dem Zertifikat liegt unsere Prüf- und Zertifizierungsordnung zugrunde und es bestätigt die Konformität des Produktes mit den oben genannten Standards und Prüfgrundlagen. Zusätzliche Anforderungen in Ländern, in denen das Produkt in Verkehr gebracht werden soll, müssen zusätzlich betrachtet werden. Die Herstellung des zertifizierten Produktes wird überwacht.
This certificate is based on our Testing and Certification Regulation and states the conformity of the product with the standards and testing requirements as indicated above. Any additional requirements in countries where the product is going to be marketed have to be considered additionally. The manufacturing of the certified product is subject to surveillance.

TÜV Rheinland LGA Products GmbH, Tillystraße 2, 90431 Nürnberg

Tel. +49 221 806-1371 e-mail. cert-validity@de.tuv.com
Fax: +49 221 806-3935 http://www.tuv.com/safety

